

# Optimization of Fuzzy-Logic controller for PV-PEM Fuel Cell Hybrid System

Mustapha Hatti, *IEEE Senior Member*, Hachemi Rahmani

UDES, Solar Equipments Development Unit, EPST / CDER, 11<sup>th</sup> National Road, Bou Ismail 42415, Tipaza Algeria

**Abstract**— The main objective of this paper is to study the feasibility to implement fuzzy logic control into an energetic hybrid system and to optimize the membership functions of the fuzzy logic controller for the PV-PEMFC hybrid system using genetic algorithm (GA). The paper deals with a fuzzy logic control strategy objective to produce electrical energy according to the demand, prone to the constraints and the dynamics of the physical load and intermittence of the energetic resource, by distributing the energy demand between the photovoltaic field and the PEM Fuel Cells system. PV-PEM Fuel Cell is described in detail as well as system configuration and components' parameters. The second section devotes to demonstrating the design process of fuzzy logic control for PV-PEM Fuel Cell hybrid System. Optimal control problem is addressed and genetic algorithm is introduced to help find a set of optimum parameters in the fuzzy logic controller, best results are obtained and good optimization of the hybrid system is highlighted.

**Keywords**- PV-PEMFC hybrid system; fuzzy logic controller; genetic algorithm; management; hydrogen

## I. INTRODUCTION

To avoid problems caused by the weather and environmental uncertainties, the reliability of a continuous production of energy from renewable sources when only one source production system model is considered, the possibility of integrating various sources creating hybrid energy solutions can greatly reduce the intermittences and uncertainties of energy production bringing a new perspective for the near future. In the literature review, a sustainable energy system has been commonly defined in terms of its energy efficiency, its reliability, and its environmental impacts [1]. The basic requirements for an efficient energy system are its ability to generate enough power for the world needs at an affordable price, clean supply, safe and reliable conditions. On the other hand, the typical characteristics of a sustainable energy system can be derived from policy definitions and objectives since they are quite similar in industrialized countries. A hybrid PV-PEMFC low power system is a suitable solution to replace batteries and to supply small electric devices placed in remote areas in particularly in the wireline and borehole operations [2].

The improvement of the efficiency in the energy production and the guaranty of reliable energy supply seem nowadays to be common interests of developed and developing countries. The application of an autonomous

hybrid energy system, typically a photovoltaic (PV)-PEMFC hybrid power system, is a promising solution to electrifying the isolated locations far from the grid. One of the main difficulties related to the hybrid structure is the management of energy flows. Resolution is indeed subject to various constraints. Given the complexity of the problem, a strategy based on an intuitive analysis of the problem of managing the flow of energy is proposed. Initially the hybrid structure and the role of controller are defined; a fuzzy logic approach management of energy flows according to the environment which ensures a continuous power regardless of load variation is planned. Simulations performed based on MATLAB<sup>®</sup> / Simulink<sup>®</sup> on this hybrid system in order to visualize flip from one mode to another [3]-[5]. The basic PV-PEMFC structure consists of a photovoltaic generator, a PEMFC fuel cell and electrolyzer. With the hybrid structure, three modes are then possible: Load mode; Normal mode and overload mode. Charging is the discharge of the fuel cell takes place independently.

## II. PV-PEMFC HYBRID SYSTEM

### A. Photovoltaic subsystem

The electric field created by the p-n junction causes the photon-generated electron-hole pairs to separate. The electrons are accelerated to n-region (N-type material), and the holes are dragged into p-region (P type material). The electrons from n-region flow through the external circuit and provide the electrical power to the load at the same time [6].

In this paper a simplified one diode model is used due its moderate complexity. The relationship between the output voltage  $V$  and the load current  $I$  can be expressed as:

$$I = I_L - I_D = I_L - I_o \left[ \exp\left(\frac{U + IR_s}{a}\right) - 1 \right] \quad (1)$$

where;  $I_L$  = light current (A);  $I_D$  = saturation current (A);  $I$  = load current (A);  $U$  = output voltage (V);  $R_s$  = series resistance (Ohm);  $a$  = thermal voltage timing completion factor (V). This model is called the four parameters model; it is simple but requires determining four parameters value which are function of temperature, load current and solar irradiance.

Based on the mathematical equations discussed before, a dynamic model for a PV module consisting 48 cells in series has been evaluated using MATLAB/Simulink. The PV array characteristic presents three important points, the short circuit current, the open circuit voltage and the optimum power delivered by the PV to an optimum load when the PV modules operate at their MPP [7]. The output of the Matlab function of photovoltaic model characteristics I/V and P/V is shown first for different irradiation levels (800; 600; 400; 200 W/m<sup>2</sup>) at 25°C in figures 2 and 3, and then for various temperatures (20; 30;40;50 °C) for 800 W/m<sup>2</sup> in figures 1 and 2 respectively. Results show excellent correspondence to the model.

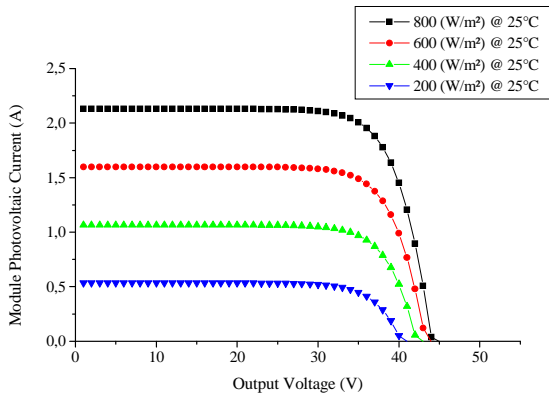

Fig.1:I/V characteristics of PV model at different irradiances and T= 25°C

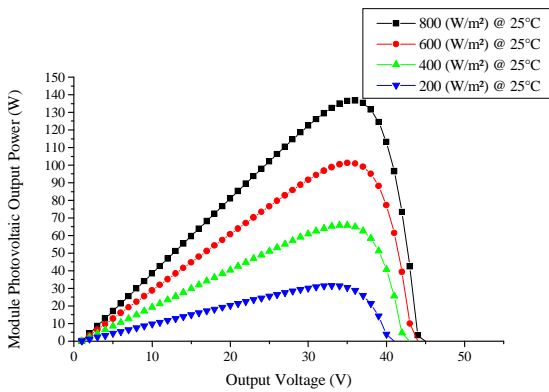

Fig.2:P/V characteristics of PV model at different irradiances and T=25°C

### B. Fuel cell subsystem

The fuel cell, as a renewable energy source, is considered one of the most promising sources of electric power. Fuel cells are not only characterized by higher efficiency than conventional power plants, but they are also environmentally clean, have extremely low emission of oxides of nitrogen and sulfur, and have very low noise.

Fuel cells are electrochemical devices that convert the chemical energy of a reaction directly into electrical energy. They have a potential to achieve a level of efficiency beyond

70% when used in a cogeneration facility. Fuel cells are classified by the type of electrolyte used in the cells and include: (1) proton exchange membrane (polymer) electrolyte fuel cell (PEMFC), (2) alkaline fuel cell (AFC), (3) phosphoric acid fuel cell (PAFC), (4) molten carbonate fuel cell (MCFC), and (5) solid oxide fuel cell (SOFC). These fuel cells are listed in the order of approximate operating temperature, ranging from 80°C for PEMFC to 1000°C for SOFC.

The typical structure of a single PEMFC is shown in Figure 3. A single cell consists of anode, cathode, electrolyte plate and current collectors with gas channels. H<sub>2</sub> and O<sub>2</sub> get through the gas channels of current collectors and arrive at the anode and cathode respectively; the reactive gases pass the diffusion layer and reach the proton exchange membrane (50-170 μm thick) Figure 3, membrane under the action of electricity. On the cathode, the oxygen diffuses towards the catalyst interface where it combines with the hydrogen protons and the electrons to form water. The electrons passing from anode to cathode produce electrical energy.

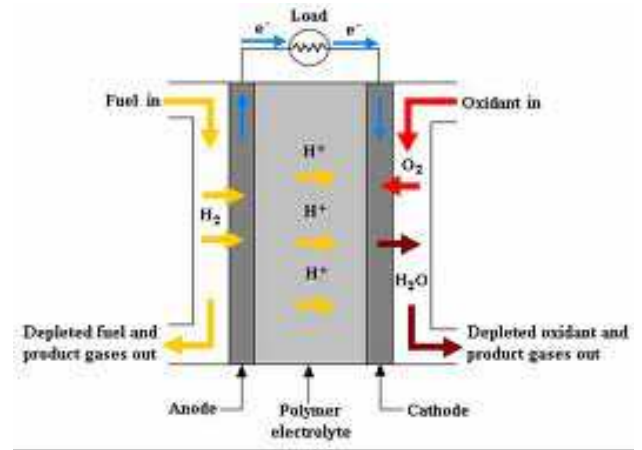

Fig.3: Schematic of PEM Fuel Cell

In the past decades, the researches on PEMFC are mainly focused on the structural design of a single cell, catalyst layer and gas diffusion layer, the manufacture of high performance membrane and catalyst, the thermal and water management of PEM fuel cells. The researchers investigated deeply the components and PEMFC system. Different static and dynamic models of PEMFC have been established on the basis of the energy, mass and momentum conservation laws [8].

The components and single cell model were founded based on the operational mechanism, and research was carried out on the working parameters (gas flow rate, pressure, humidity, cell temperature and moisture content) affecting the output voltage. But the large number of experimental parameters in the models of components and single cell lead to overall decrease in performance, figures 4 and 5. Moreover, the theoretical and simplified conditions in modeling cause the precision to decline greatly; and the expressions of model are so complex that it is difficult to apply them in the design of PEMFC system [9], [10].

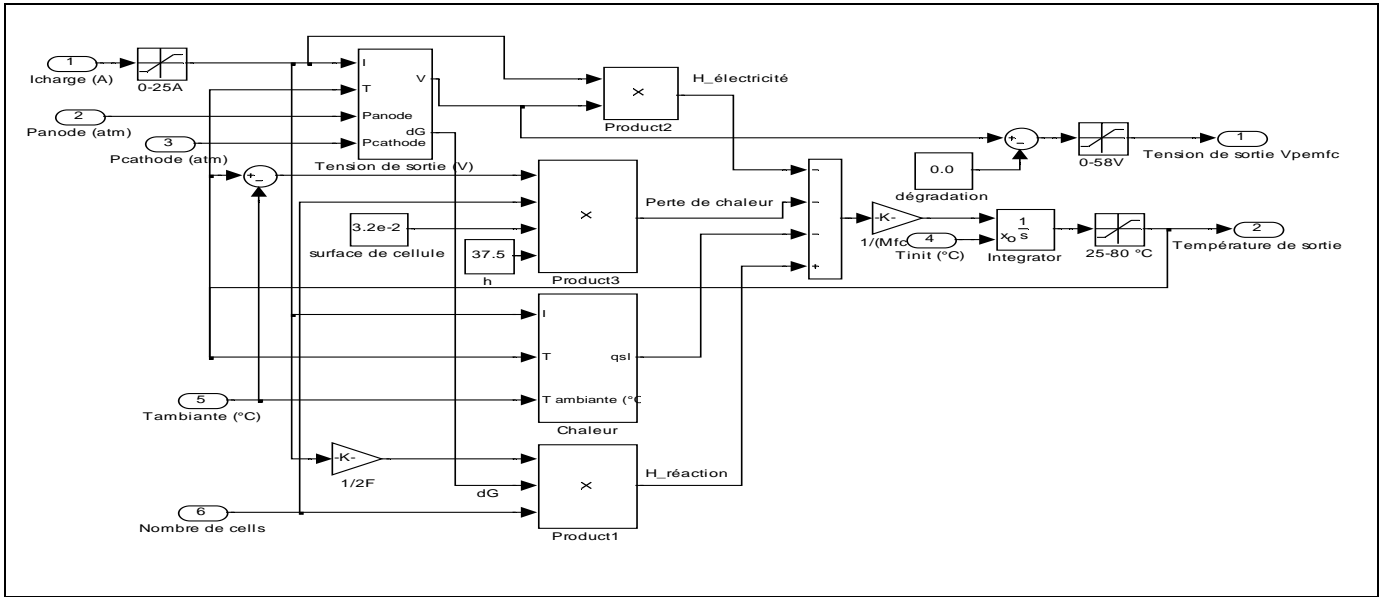

Fig.4:PEM Fuel Cell Model / MATLAB/Simulink

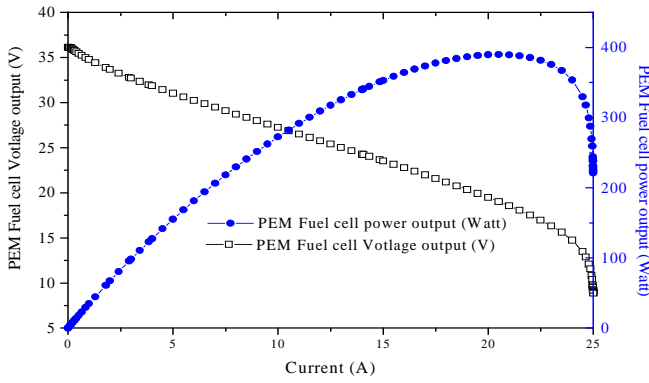
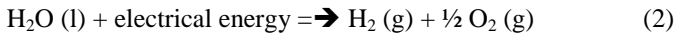

Fig.5:P/I and V/I Characteristics of PEM Fuel Cell

### C. Electrolyser and Hydrogen Tank subsystem

An electrolyzer is advice that produces hydrogen and oxygen from water. The electrochemical reaction of water electrolysis is given by:



There are three principal types of water electrolyser: alkaline (referring to the nature of its liquid electrolyte), proton-exchange membrane (referring to its solid polymeric electrolyte), and solid-oxide (referring to its solid ceramic electrolyte). The alkaline and PEM electrolysers are well proven devices with thousands of units in operation, while the solid-oxide electrolyser is as yet unproven. The PEM electrolyser is particularly well suited to highly distributed applications. The alkaline electrolyser currently dominates global production of electrolytic hydrogen.

Alkaline water electrolysis is the dominating technology today

According to faraday' law, hydrogen production rate of an electrolyzer can be obtained as:

$$n_{\text{H}_2} = \frac{\eta_F n_C i_e}{2F} \quad (3)$$

where: F: Faraday constant,  $i_e$ : Electrolyser current,  $n_C$ : The number of electrolyser cells in series,  $\eta_F$ : Faraday efficiency.  $n_{\text{H}_2}$ : Produced hydrogen moles per second.

One of the hydrogen storage techniques is physical hydrogen storage, which involves using tanks to store either compressed hydrogen gas or liquid. The hydrogen storage model based on Eq (4) directly calculates the tank pressure using the ration of hydrogen flow in the tank. The produced hydrogen is stored in the tank, whose system dynamic can be compressed as follow:

$$P_b - P_{bi} = z \frac{N_{\text{H}_2} RT_b}{M_{\text{H}_2} V_b} \quad (4)$$

where:  $M_{\text{H}_2}$ : Molar mass of hydrogen;  $N_{\text{H}_2}$ : Hydrogen moles per second delivered to the storage tank;  $P_b$ : Pressure of tank.  $P_{bi}$ : Initial pressure of the storage tank; R: Universal gas constant;  $T_b$ : Operating temperature;  $V_b$ : Volume of the tank; z: Compressibility factor as a function of pressure; the hydrogen' state-of-storage (SHS) is therefore:

$$\text{SHS} = \frac{P_b}{P_{b \max}} \quad (5)$$

where:  $P_p$ : Pressure of tank;  $P_{bmax}$ : is the maximum Pressure of tank [11].

### III. FUZZY LOGIC CONTROLLER AND GENETIC ALGORITHM

The fuzzy PID controller is a structure obtained by interconnection of a classical PID controller and a fuzzy controller. The control system achieved out consists of two parts working in series, and the increment of control achieved by this controller is the sum of two increments generated by the two parties forming. Since, the wanted behaviour is well known and can be described using linguistic variables, the use of a FLC seems appropriate. However, it is shown that the method of the average maximum ensures better performance of transition [12]. It emerges through these comparative studies that the choice of a better method of defuzzification is highly dependent on the particular application, and is the case of the maximum likelihood method which proves to be very effective for control problems. Simulink block that focused energy management of a PV-PEMFC hybrid system is implemented:

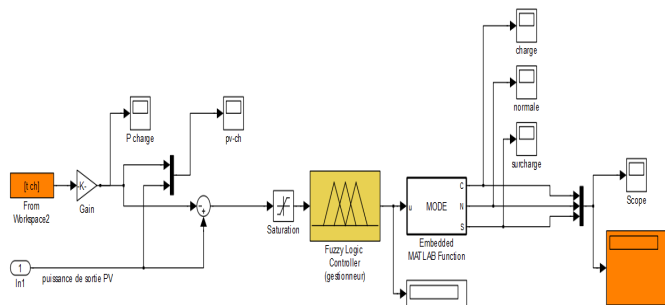

Fig.6: Energy management system bloc diagram

This system acts as a fuzzy controller that controls the operation mode of our hybrid system regardless of load variations, and photovoltaic generator, in figure 6. The result is obtained varies with the error representing the difference between load power and power of photovoltaic generator can therefore defined three operating mode in this system, namely:

- **Normal mode:** In this mode, the power of positive charge is below the maximum power from the main source, in this mode the photovoltaic generator can only feed the load.
- **Overload:** In this mode the power absorbed by the load is above the main power source, the controller can recognize the power of the fuel cell to the load.

**Charge Mode (recovery):** In this mode, the power of a PV generator exceeds the load power. The changes in operating mode only occur when the load demand is at the boundary of mode Change. This type of Controller presents many advantages for such system.

#### A. Genetic algorithm optimisation

For the current study, the objective function is the net power, which is defined as the ratio of the net electrical power output of the system compared to the energy power demand to the system, which is quantified by the value of the variable

that is to be minimized. Once a fuzzy logic control structure has been chosen and modeled using a gain parameters representation, its parameters have been tuned using genetic algorithm to match the real power demand in each corresponding configuration.

In this section, the implementation of the optimization of fuzzy PID controller parameters from the use of GAs is described. The objective is always to find the optimized set of parameters  $P = [P1, P2, P3, P4 \text{ and } P5]$ , so that the response of the closed loop system is stable and robust as possible as for any variations of load profiles, temperature and solar irradiance of the PV-PEMFC hybrid system.

Summarily, the methodology of the genetic algorithm consists of the following steps:

1. Generate a random population and evaluate the fitness of each member ;
2. Define the termination conditions ;
3. Select parents if the crossover condition is met, select crossover parameters and apply crossover ;
4. Select member if the mutation condition is met, select mutation parameters and apply mutation ;
5. Evaluate the fitness of the offspring and update the population ;
6. Repeat steps 2-6, until the termination conditions are satisfied [13]-[16].

### IV. RESULTS AND COMMENTS

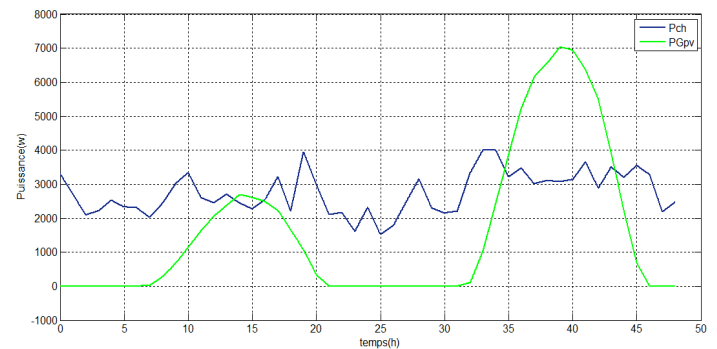

Figure 7 shows the power demand profile and solar resources.

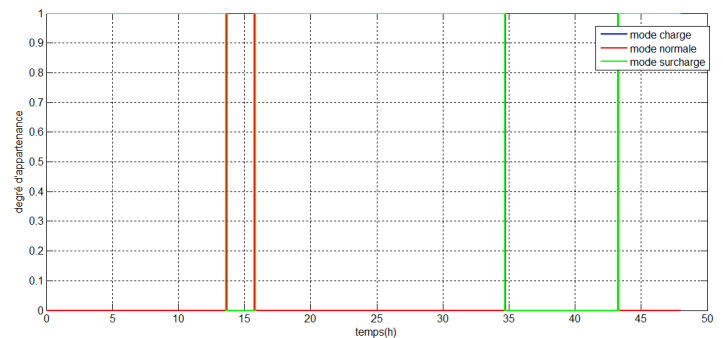

Figure.8: Fuzzy logic control operations

Results are identified by the amount of hydrogen produced by the excess power of PV-PEM fuel cell hybrid system.

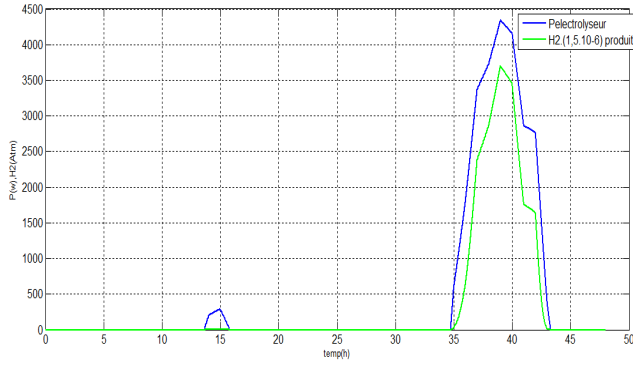

Fig.9: Load mode and Hydrogen produced

Table.1 Options used in genetic algorithm

parameter	symbol	value
Population size	$n_p$	20
Generation number	$n_g$	100
Selection coefficient	$q_s$	1.5e-3
Probability of crossover	$p_c$	0.8
Mutation probability	$p_m$	1.2

Table.1 shows the values of the main parameters used for the implementation of the proposed genetic algorithm. The choice of these parameters is based on extensive testing of performance and convergence of the GA. A realistic uniform type of mutation is used here. Each individual in a population is changing with a certain probability  $p_m$  a random value drawn from a uniform distribution on the interval  $\delta$  possible solutions in a specific range of mutation  $D_m$ . In our case, we consider that interval  $D_m$  is identical to the interval  $\delta$ . The initial population is randomly selected in a search space  $\delta$ . The range of each variable  $\delta$  is determined by trial and error that this choice is not important enough for the convergence of the solution to a global optimum.

The steps of the genetic algorithm are executed until the value of the fitness function of individuals do not evolve more (tolerance function  $<\delta$ ), and when the maximum number of generations  $n_g$  is reached. The global error is the sum of the square error between the set point and the system response for the different samples  $BF$  is taken as an objective function to be minimized:

$$f_{obj}(x_1 x_2 x_3 x_4 x_5) = \sum_{k=0}^n (1 - I(k))^2 \quad (6)$$

Where  $I(k)$  is the system response to  $BF$ .

In this paper the cross is used in two points. Crossings are planned with two individuals of the same population (Pa1, Pa2), generally known fathers. As a result of this crossover, we have two new individuals (e1, e2). This type of crossing is defined as follows:

$R_c$  where is a weighting variable random between 0 and 1. The number arithmetic of the cross times must be applied for each generation is defined as the probability of cross  $p_c$ .

It is quite clear that the PEM fuel cell provides power for the load request whatever variation is, where a difference has reached the following values as such:

At time  $t=0h \rightarrow p=550w$ ;  $t=4h \rightarrow p=470w$ ;  $t=8h \rightarrow p=375w$   
 $t=20h \rightarrow p=440w$ ;  $t=24h \rightarrow p=370w$ ;  $t=28h \rightarrow p=275w$ ;  $t=32h \rightarrow p=250w$ ;  $t=48h \rightarrow p=400w$ , depicted in figure.10.

$P1= 8.147237e-001$ ,  $P2 = 6.557407e-001$ ,  $P3 = 4.387444e-001$ ,  $P4=7.512671e-001$ ,  $P5 = 3.516595e-001$  Found algebraic loop containing.

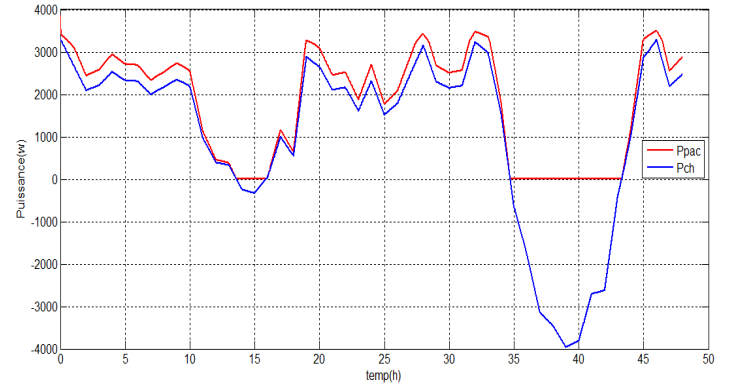

Fig.10: Overload mode

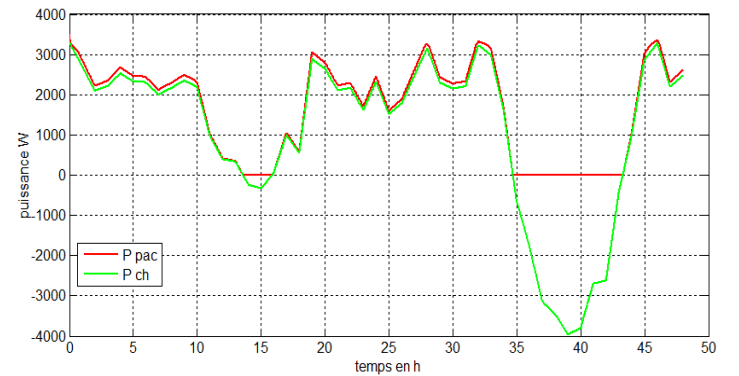

Fig.11: PEM Fuel Cell power distribution within 48 hours

At time  $t=0h \rightarrow p=200w$ ;  $t=4h \rightarrow p=140w$ ;  $t=8h \rightarrow p=130w$ ;  
 $t=20h \rightarrow p=155w$ ;  $t=24h \rightarrow p=135w$ ;  $t=28h \rightarrow p=125w$ ;  $t=32h \rightarrow p=95w$ ;  $t=48h \rightarrow p=140w$ , depicted in figure.11.

The optimum configuration of the hybrid system proposed is presented; output of the Fuzzy logic controller is depicted in

figure.8 following the behavior of the energetic system. The objective function has been significantly improved in figures 9-11. The improvement is more noticeable in the beginning of the optimization process; this flat behavior indicates that the overall iterative optimization scheme has practically converged. Comparison between the simulated results using fuzzy logic controller model are shown for along two days configuration, in order to validate the model within the fine tuning genetic algorithm of interesting parameters.

## V. CONCLUSIONS

In this paper the set model of the stand alone PV-PEM Fuel Cell hybrid system is analyzed and then one fuzzy logic controller is considered. A genetic algorithm is introduced to fine-tune parameters of membership functions in the fuzzy logic controller. The results show that the hybrids with the fine-tuned fuzzy logic controller would have a higher fuel economy and better system efficiency compared with the rule-based controller. The fuzzy logic controller is then designed to handle with energy distribution and management. To achieve improved equivalent fuel consumption, genetic algorithm is implemented to fine-tune the membership functions. The control effects are compared between different control strategies, e.g. rule-based control and fine-tuned fuzzy logic control. The results point out those hybrids energetic systems with the proposed strategy can improve fuel economy without sacrificing system performance.

## ACKNOWLEDGMENT

The author wish to thank the General Directorate of Scientific Research and Technological Development (DGRSDT) for financial support for this project under the National Research Program code: NRP 10/nu42/4729.

## REFERENCES

- [1] Alanne, K. and Saari, A. Distributed energy generation and sustainable development. *Renewable & Sustainable Energy Reviews*, vol. 10, issue 6, 2006, pp.539-558.
- [2] M. Hatti, A. Meharrar, M. Tioursi Power management strategy in the alternative energy photovoltaic/PEM Fuel Cell hybrid system *Renewable and Sustainable Energy Reviews*, vol. 15, Issue 9, 2011,pp. 5104-5110.
- [3] S.V.G. Oliveira, I. Barbi, "A Three-Phase Step-Up DC-DC Converter With a Three-Phase High-Frequency Transformer for DC Renewable Power Source Applications ," *IEEE Trans. on Industrial Electronics*, vol. 58, no. 8, 2011, pp. 3567 - 3580 .
- [4] Tao Zhou, B. Francois, "Energy Management and Power Control of a Hybrid Active Wind Generator for Distributed Power Generation and Grid Integration ," *IEEE Trans. on Industrial Electronics*, vol. 58, no. 1, 2011, pp. 95 – 104.
- [5] P.K. Goel, B. Singh, S.S. Murthy, N. Kishore, "Isolated Wind-Hydro Hybrid System Using Cage Generators and Battery Storage ," *IEEE Trans. on Industrial Electronics*, vol. 58, no. 4, 2011, pp. 1141 - 1153.
- [6] Qiang Mei, Mingwei Shan, Liying Liu, J.M. Guerrero, "A Novel Improved Variable Step-Size Incremental-Resistance MPPT Method for PV Systems ," *IEEE Trans. on Industrial Electronics*, vol. 58, no. 6, 2011, pp. 2427 – 2434.
- [7] I.Colak, E. Kabalci, G.Bal, Parallel DC-AC conversion system based on separate with solar farms MPPT control, 8th IEEE International Conference on Power Electronics and ECCE Asia (ICPE & ECCE), 2011, pp. 1469 – 1475.
- [8] Qi Li, Weirong Chen, Youyi Wang, Shukui Liu, Junbo Jia, "Parameter Identification for PEM Fuel-Cell Mechanism Model Based on Effective Informed Adaptive Particle Swarm Optimization ," *IEEE Trans. on Industrial Electronics*, vol. 58, no. 6, 2011, pp. 2410 – 2419.
- [9] F. Segura, J.M. Andujar, E. Duran, "Analog Current Control Techniques for Power Control in PEM Fuel-Cell Hybrid Systems: A Critical Review and a Practical Application ," *IEEE Trans. on Industrial Electronics*, vol. 58, no. 4, 2011, pp. 1171 - 1184 .
- [10] F. Segura, J.M. Andujar, E. Duran, "Analog Current Control Techniques for Power Control in PEM Fuel-Cell Hybrid Systems: A Critical Review and a Practical Application ," *IEEE Trans. on Industrial Electronics*, vol. 58, no. 4, 2011, pp. 1171 - 1184.
- [11] G.R. Biswal, R.P. Maheshwari, M.L. Dewal, " Modeling, Control, and Monitoring of SR<sup>3</sup>S -Based Hydrogen Cooling System in Thermal Power Plant ," *IEEE Trans. on Industrial Electronics*, vol. 59, no. 1, 2012, pp. 562-570.
- [12] T. Azib, O. Bethoux, G. Remy, C. Marchand, E. Berthelot, "An Innovative Control Strategy of a Single Converter for Hybrid Fuel Cell/Supercapacitor Power Source ," *IEEE Trans. on Industrial Electronics*, vol. 57, no. 12, 2010, pp. 4024 - 4031.
- [13] Ruey-Jing Lian, "Intelligent Controller for Robotic Motion Control ," *IEEE Trans. on Industrial Electronics*, vol. 58, no. 11, 2011, pp. 5220 – 5230.
- [14] Shun-Chung Wang, Yi-Hwa Liu, "A Modified PI-Like Fuzzy Logic Controller for Switched Reluctance Motor Drives ," *IEEE Trans. on Industrial Electronics*, vol. 58, no. 5, 2011, pp. 1812 - 1825.
- [15] H.M. Hasanien, "Particle Swarm Design Optimization of Transverse Flux Linear Motor for Weight Reduction and Improvement of Thrust Force ," *IEEE Trans. on Industrial Electronics*, vol. 58, no. 9, 2011, pp. 4048 - 4056.
- [16] A. Yahyaoui, N. Fnaiech, F. Fnaiech, "A Suitable Initialization Procedure for Speeding a Neural Network Job-Shop Scheduling ," *IEEE Trans. on Industrial Electronics*, vol. 58, no. 3, 2011, pp. 1052 – 1060.